

INSERTABLE COUNTERSINK INSERTS

PATENT Nos. D396,865 & 5,827,019

SEE PAGE #7 FOR STANDARD HOLDERS

LEFT HAND INSERTS

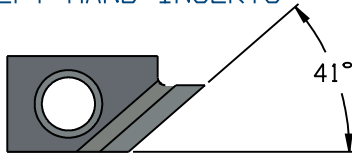

41° INSERTS	
L.H. INSERT No.	R.H. INSERT No.
CSI-41	CSI-41R

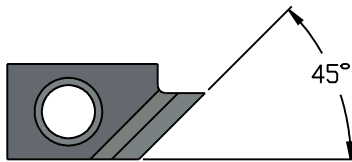

45° INSERTS	
L.H. INSERT No.	R.H. INSERT No.
CSI-45	CSI-45R

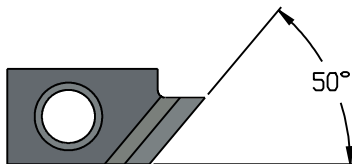

50° INSERTS	
L.H. INSERT No.	R.H. INSERT No.
CSI-50	CSI-50R

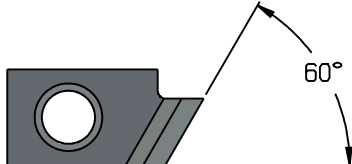

60° INSERTS	
L.H. INSERT No.	R.H. INSERT No.
CSI-60	CSI-60R

RIGHT HAND INSERTS

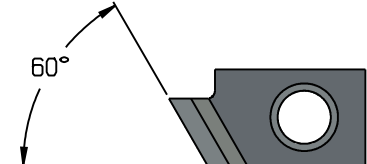
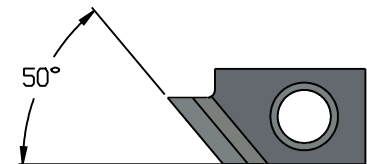
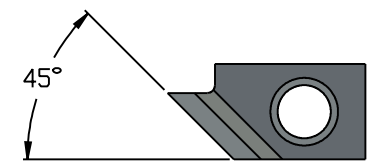
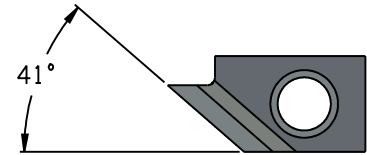

STANDARD INSERTS IN SPECIAL TOOLHOLDERS

CREATE ANY INCLUDED ANGLE AND DIAMETER WITH A SPECIAL HOLDER,
USING A STANDARD INSERT, DESIGNED TO YOUR SPECIFICATIONS.

SAMPLES

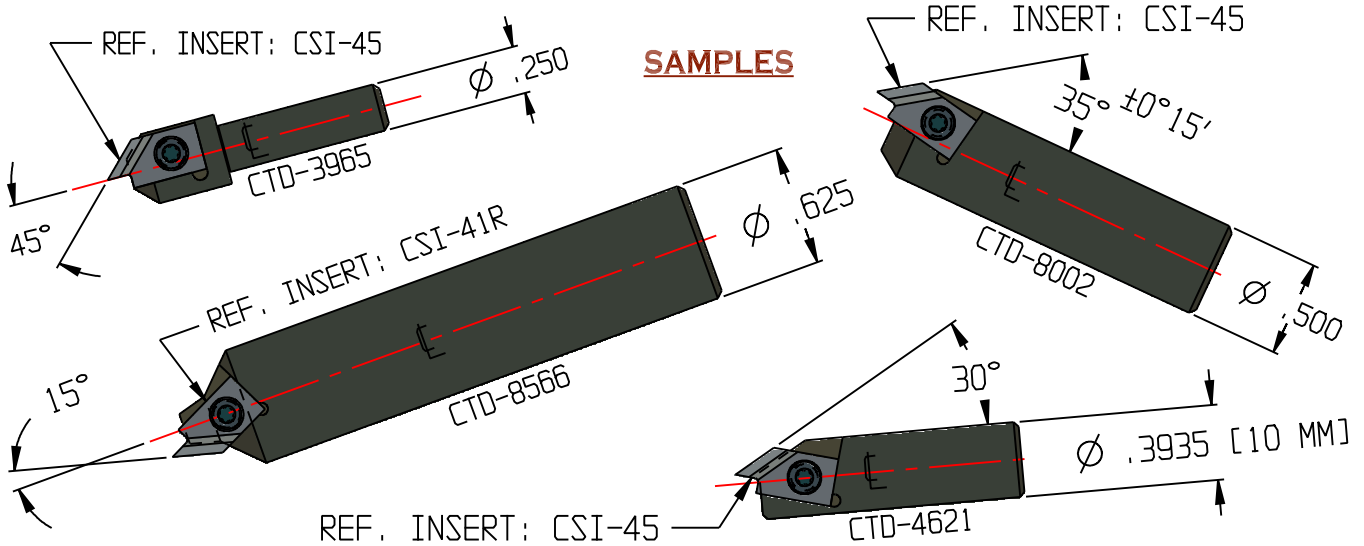

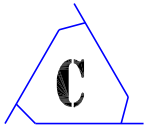

INSERTED COUNTERSINK TOOLHOLDERS

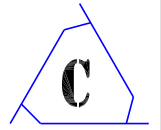

PATENT Nos. D396,865 & 5,827,019

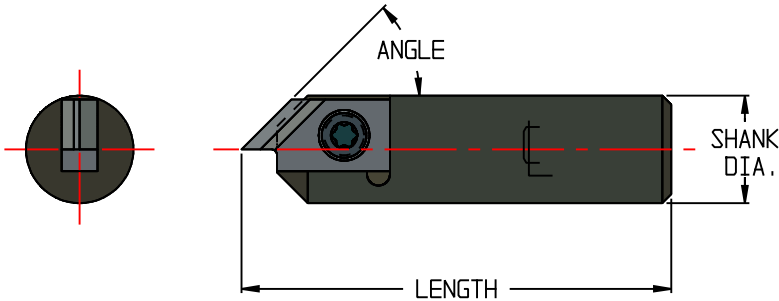

SEE INSERTS ON PAGE #6

FEATURES

- * COUNTERSINK RANGE FROM $\varnothing.035$ TO $\varnothing.325$
- * BACKWORKING LEFT OR RIGHT HAND CUTTING
- * CHAMFERING BACK END OF PART I.D.
- * THREE OTHER LENGTHS ARE AVAILABLE AS STANDARDS. 1.0, 2.0, 2.5. ORDERING EXAMPLE CSH-90-500-1.0, CSH-90-500-2.0, CSH-90-500-2.5
- * SPECIAL ORDER LENGTHS ARE AVAILABLE FOR HOLDERS ON THIS PAGE.
- * SPECIAL HOLDERS CAN BE MADE TO ACCOMMODATE LARGER PART COUNTERSINK DIAMETER RANGES

LEFT HAND		LEFT HAND SHOWN					
INCLUDED ANGLE	TOOLHOLDER No.	TOOL LENGTH	SHANK DIA.	INSERT ANGLE	INSERT NO.	SCREW No.	WRENCH No.
82°	CSH-90-375	1.5	.375	41°	CSI-41	CTD-3126	CTD-3344
90°	CSH-90-375	1.5	.375	45°	CSI-45	CTD-3126	CTD-3344
100°	CSH-90-375	1.5	.375	50°	CSI-50	CTD-3126	CTD-3344
120°	CSH-120-375	1.5	.375	60°	CSI-60	CTD-3126	CTD-3344
90°	CSH-90-437	1.5	.4375	45°	CSI-45	CTD-3126	CTD-3344
82°	CSH-90-500	1.5	.500	41°	CSI-41	CTD-3126	CTD-3344
90°	CSH-90-500	1.5	.500	45°	CSI-45	CTD-3126	CTD-3344
100°	CSH-90-500	1.5	.500	50°	CSI-50	CTD-3126	CTD-3344
120°	CSH-120-500	1.5	.500	60°	CSI-60	CTD-3126	CTD-3344
90°	CSH-90-625	1.5	.625	45°	CSI-45	CTD-3126	CTD-3344
90°	CSH-90-750	1.5	.750	45°	CSI-45	CTD-3126	CTD-3344
90°	CSH-90-10MM	1.5	.3937	45°	CSI-45	CTD-3126	CTD-3344

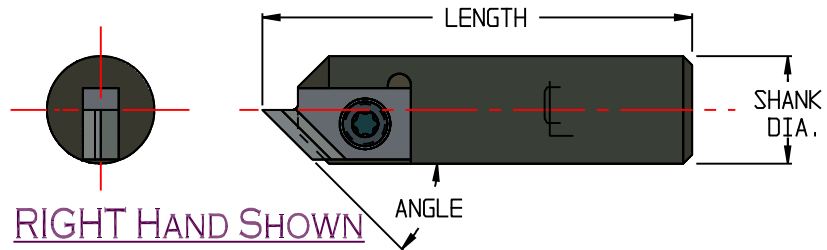

SEE INSERTS ON PAGE #6

RIGHT HAND		RIGHT HAND SHOWN					
INCLUDED ANGLE	TOOLHOLDER No.	TOOL LENGTH	SHANK DIA.	INSERT ANGLE	INSERT NO.	SCREW No.	WRENCH No.
82°	CSH-90-375R	1.5	.375	41°	CSI-41R	CTD-3126	CTD-3344
90°	CSH-90-375R	1.5	.375	45°	CSI-45R	CTD-3126	CTD-3344
100°	CSH-90-375R	1.5	.375	50°	CSI-50R	CTD-3126	CTD-3344
120°	CSH-120-375R	1.5	.375	60°	CSI-60R	CTD-3126	CTD-3344
90°	CSH-90-437R	1.5	.4375	45°	CSI-45R	CTD-3126	CTD-3344
82°	CSH-90-500R	1.5	.500	41°	CSI-41R	CTD-3126	CTD-3344
90°	CSH-90-500R	1.5	.500	45°	CSI-45R	CTD-3126	CTD-3344
100°	CSH-90-500R	1.5	.500	50°	CSI-50R	CTD-3126	CTD-3344
120°	CSH-120-500R	1.5	.500	60°	CSI-60R	CTD-3126	CTD-3344
90°	CSH-90-625R	1.5	.625	45°	CSI-45R	CTD-3126	CTD-3344
90°	CSH-90-750R	1.5	.750	45°	CSI-45R	CTD-3126	CTD-3344
90°	CSH-90-10MMR	1.5	.3937	45°	CSI-45R	CTD-3126	CTD-3344